

PARTS LIST AND ASSEMBLY INFORMATION

REVISIONS

REV.	DESCRIPTION	DATE	CMPLT. BY	APPRV.

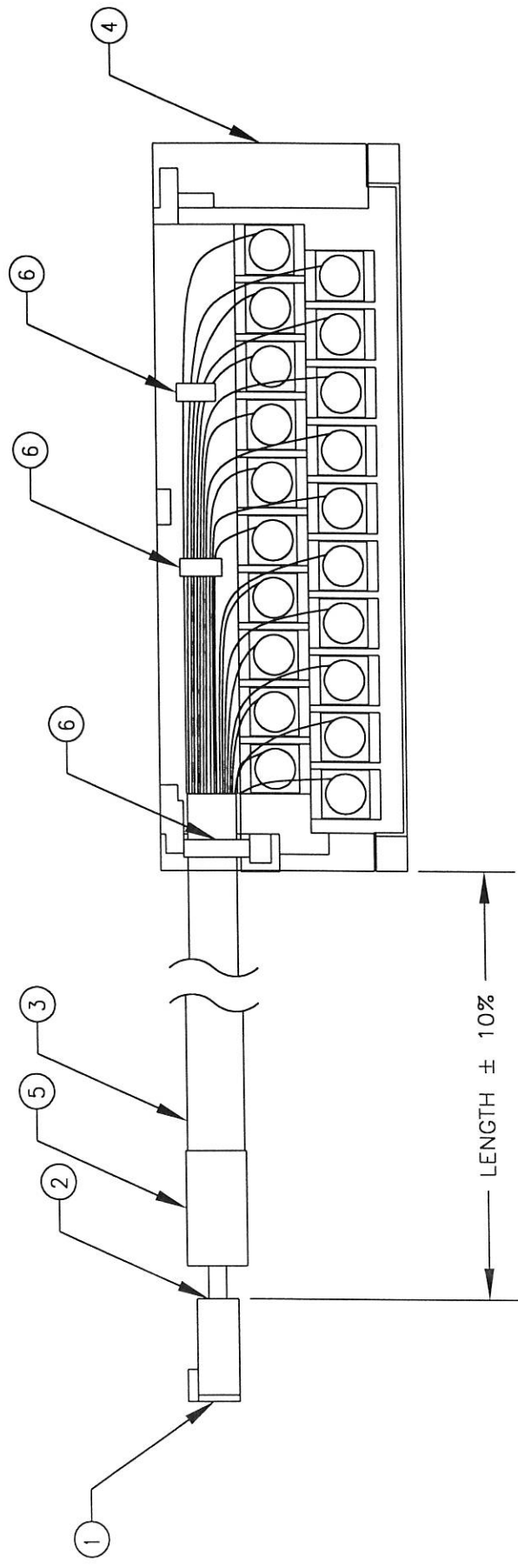

NOTES:

- CUT AND STRIP CABLE AS REQUIRED TO ACHIEVE LENGTH SPECIFIED IN TABLE.
- CUT UNUSED WIRE ENDS BACK TO JACKET BEFORE HEATING SHRINK TUBING.

PARTS LIST		
BUB. #	DESCRIPTION	QTY.
1	CONNECTOR 20-PIN FEMALE	1
2	CRIMP AND POKE TERMINAL	20
3	CABLE 20-COND 22AWG	A/R
4	TERMINAL BLOCK GE 90-30	1
5	SHRINK TUBING 1/2"OD	100mm
6	TIE WRAP 4" NYLON	3

CATALOG NO.	LENGTH (m)
998169	0.5
998170	1.0
998171	1.5
998172	2.0

 WEIDMÜLLER INC. 821 SOUTHLAKE BLVD. RICHMOND, VIRGINIA 23236	CAT. NO. VARIOUS DRWN BY SB APPROVED <i>D.K.C.</i> REL. DATE 3/31/97	TITLE SWINGARM CABLE ASSEMBLY GE IC693MDL930 RELAY OUTPUT	TOLERANCE ON : .x = +/- 0.508 mm .xx = +/- 0.254 mm .xxx = +/- 0.127 mm .x = +/- .30 UNLESS OTHERWISE SPECIFIED ALL DIMENSIONS ARE IN MILLIMETERS () INDICATES REFERENCE DIMENSIONS	PROPRIETARY RIGHTS : THIS DOCUMENT INCLUDES DESIGN AND ENGINEERING CONCEPTS WHICH ARE THE PROPERTY OF WEIDMULLER INC. AND THIS DOCUMENT OR ITS CONTENTS MAY NOT BE DISCLOSED TO OTHERS, REPRODUCED, COPIED, OR USED WITHOUT WRITTEN AUTHORITY FROM WEIDMULLER INC. IN RICHMOND, VIRGINIA.
	DISTRIBUTION: <input checked="" type="checkbox"/> P/N <input checked="" type="checkbox"/> DWG. <input type="checkbox"/> PROD. <input checked="" type="checkbox"/> INSP. <input type="checkbox"/> OTHER	SCALE: DO NOT SCALE	SIZE: A SHEET 1 OF 2	DRAWING NUMBER 1100288 REV. 0
PRODUCTION RELEASE PAGE 1		PRODUCTION RELEASE PAGE 1		