

# mikroXMEGA™

Manual

*All MikroElektronika's development systems represent irreplaceable tools for programming and developing microcontroller-based devices. Carefully chosen components and the use of machines of the last generation for mounting and testing thereof are the best guarantee of high reliability of our devices. Due to simple design, a large number of add-on modules and ready to use examples, all our users, regardless of their experience, have the possibility to develop their projects in a fast and efficient way.*

Development System

 **MikroElektronika**

SOFTWARE AND HARDWARE SOLUTIONS FOR EMBEDDED WORLD ...making it simple

# mikroXMEGA

The mikroXMEGA is a compact development system that enables you to experiment with the ATxmega128A1 microcontroller from Atmel®.

## Key features:

- Bootloader program loaded into the ATxmega128A1 microcontroller;
- USB-UART communication;
- JTAG connector;
- External power supply 3.3V.

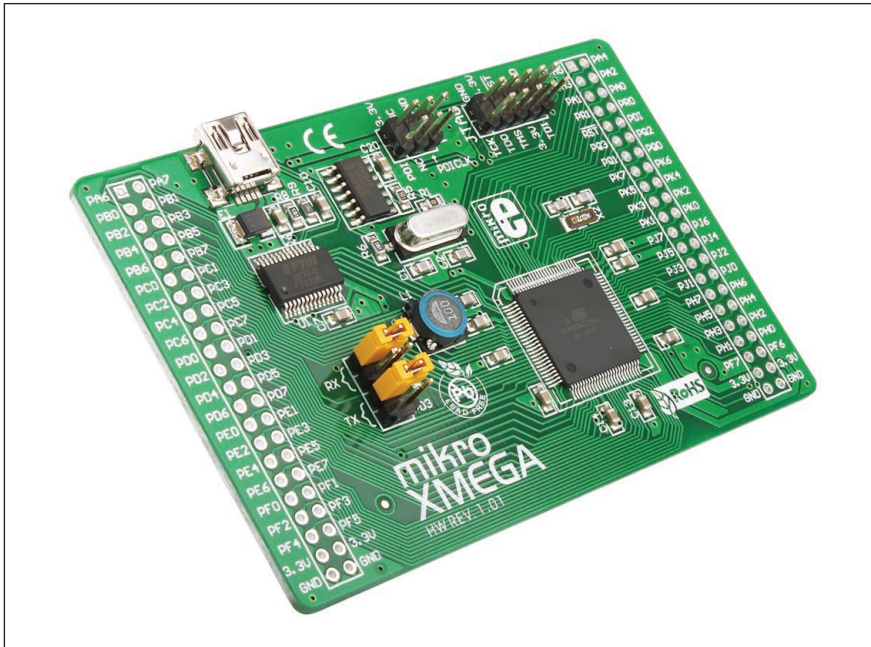

Figure 1: mikroXMEGA development system

## How to connect the development system?

The mikroXMEGA development system can be easily connected to external devices via connectors and pads supplied on the board. The USB connector is used to connect the USB-UART module of the development system to a PC. In order to use the USB-UART module, it is necessary to select which UART module of the microcontroller will be used. This is done via jumpers J1-J4. In order to use PC2 (RX) and PC3 (TX) pins, jumpers J1 and J3 should be placed. Likewise, in order to use PD2 (RX) and PD3 (TX) pins, jumpers J2 and J4 should be placed.

The CN4 (PDI) is used for programming/debugging via PDI interface. The CN5 (JTAG) connector is used for programming/debugging via JTAG interface.

The CN1 and CN3 pads enable the microcontroller pins to be easily accessed. The 3.3V power supply voltage is supplied to the pads marked 3.3V (+3.3V) and GND.

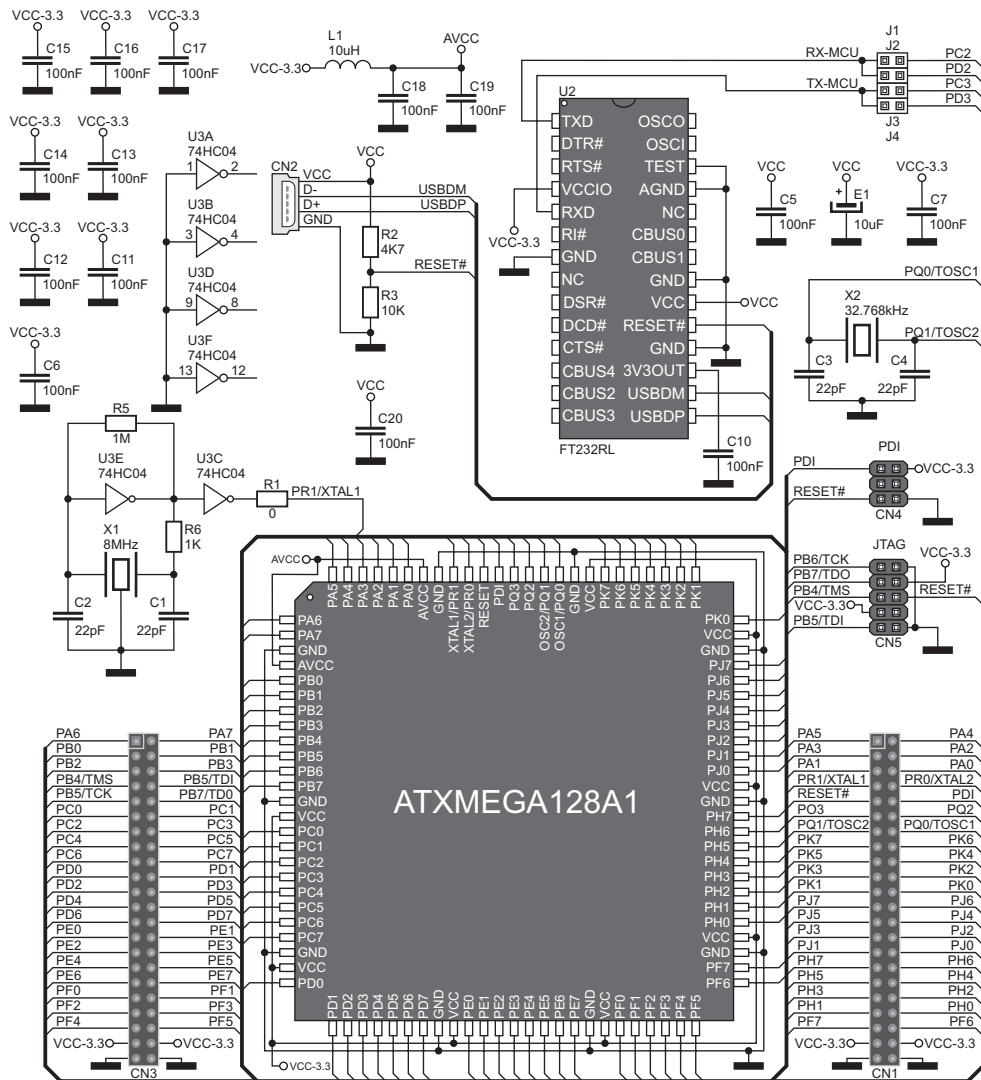

Figure 2: mikroXMEGA development system connection schematic

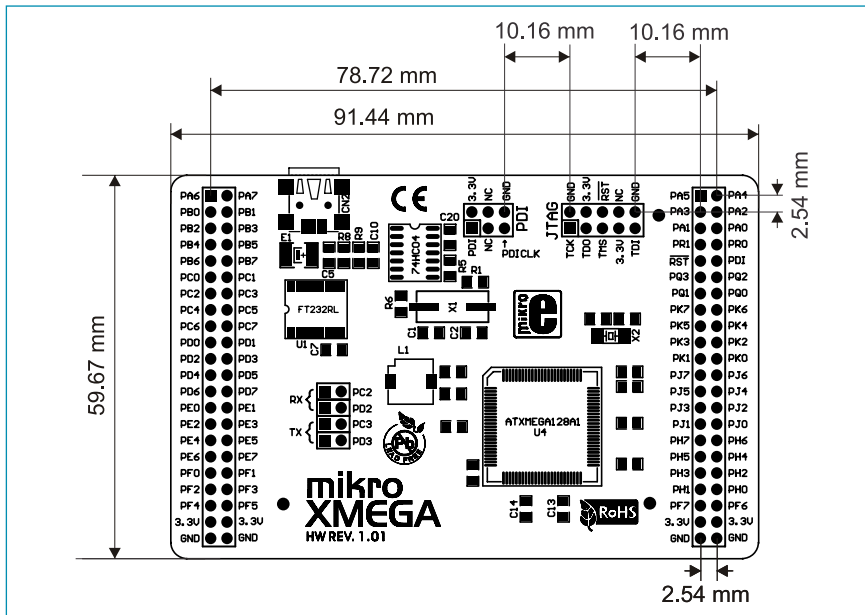

Figure 3: Dimensions of the mikroXMEGA development system

## How to program the microcontroller?

### STEP 1: Connecting the development system to a PC

The ATxmega128A1 microcontroller is programmed via the bootloader program stored in the microcontroller memory. Connect the development system to a PC via the USB connector CN2. Power the board via two pads 3.3V and GND.

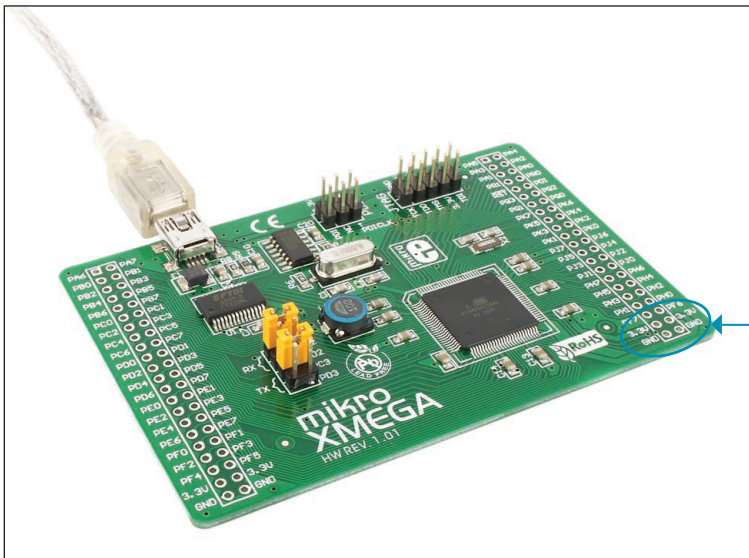

Figure 4: Programming the microcontroller

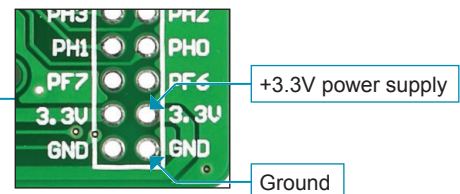



Figure 5: Powering the board

## STEP 2: Starting up the mikroElektronika Bootloader program

Download the mikroElektronika USB HID Bootloader program from Mikroelektronika's website at: [http://www.mikroe.com/eng/downloads/get/1271/mikrobootloader\\_xmega\\_v101.zip](http://www.mikroe.com/eng/downloads/get/1271/mikrobootloader_xmega_v101.zip)

Unzip the file, then double click on the appropriate icon  mikroBootloader  
Bootloader tool for mikroElektr...  
mikroElektronika

## STEP 3: Program settings

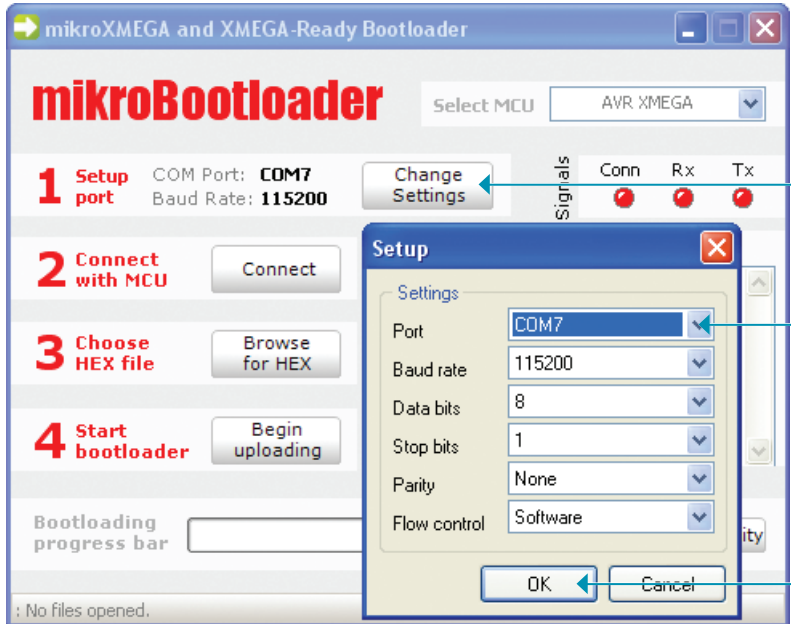

1 **Setup port** COM Port: **COM7**  
Baud Rate: **115200**

2 **Connect with MCU** Connect

3 **Choose HEX file** Browse for HEX

4 **Start bootloader** Begin uploading

Bootloading progress bar

Settings

Port: COM7

Baud rate: 115200

Data bits: 8

Stop bits: 1

Parity: None

Flow control: Software

OK Cancel

Click on the Change Settings button

Select the COM port on the PC that the development system is connected to

Click on the OK button

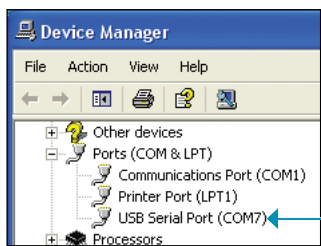

Device Manager

File Action View Help

Ports (COM & LPT)

Communications Port (COM1)

Printer Port (LPT1)

USB Serial Port (COM7)

Select the appropriate COM port from the drop-down list

The Device Manager on your PC contains information about which COM port is used for USB communication with the development system. The COM7 port is used here.

## STEP 4: Connecting

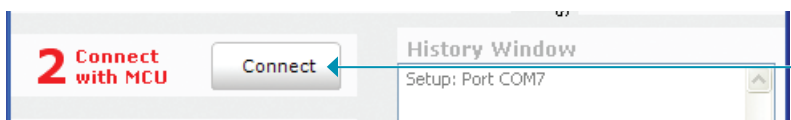

2 **Connect with MCU** Connect

History Window

Setup: Port COM7

Click on the Connect button within 5s after the development system is connected to PC

## STEP 5: Browsing for .hex file

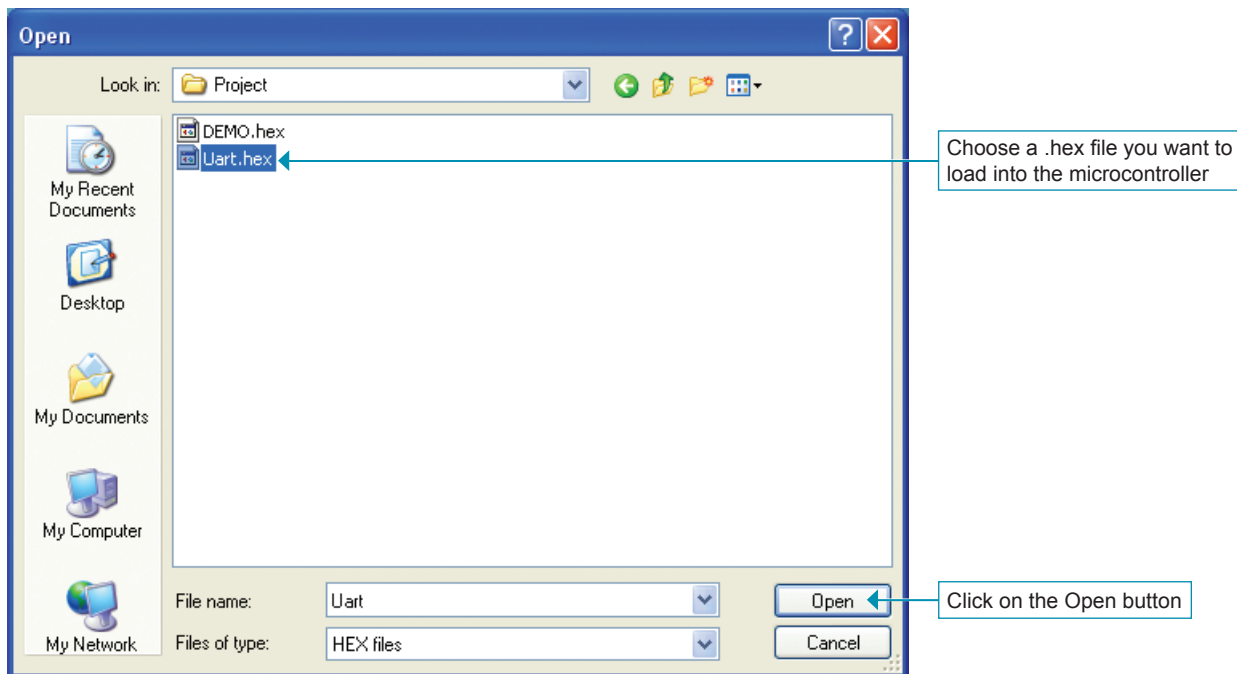

## STEP 6: Uploading the .hex file into the microcontroller



## STEP 7: Resetting the microcontroller

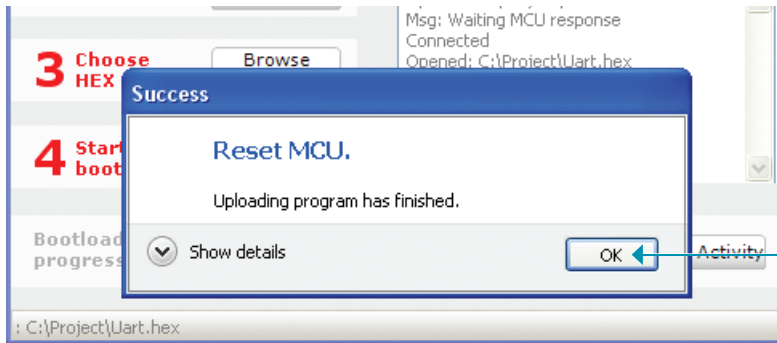

After uploading the .hex file into the microcontroller, it is necessary to reset the development system by turning it off for a few seconds and turning it on again. After that, the microcontroller supplied on the development system has been programmed and ready for use.

Click on the OK button



**MikroElektronika**  
SOFTWARE AND HARDWARE SOLUTIONS FOR EMBEDDED WORLD ...making it simple

If you want to learn more about our products, please visit our website at [www.mikroe.com](http://www.mikroe.com)

If you are experiencing some problems with any of our products or just need additional information, please place your ticket at [www.mikroe.com/en/support](http://www.mikroe.com/en/support)

If you have any questions, comments or business proposals, do not hesitate to contact us at [office@mikroe.com](mailto:office@mikroe.com)